

APPENDIX T - OFFICE OF INFORMATION TECHNOLOGY EQUIPMENT, INFRASTRUCTURE AND WIRING STANDARDS

- 1. General**
- 2. Special Requirements**
- 3. Entrance Facilities**
- 4. General Telecommunications Rooms Requirements**
- 5. Main Equipment Rooms**
- 6. Communications Rooms**
- 7. Terminal Space/Satellite Rooms**
- 8. Raceway/Tray Systems**
- 9. Outlet Facilities**
- 10. OIT Outlet Labeling Scheme**
- 11. Communications/Terminal Room Termination Requirements**
- 12. Fiber Optic Cable**
- 13. Small Form/Modular Style Fiber Standards**
- 14. Testing**
- 15. Documentation**
- 16. Power Supply**
- 17. Private Local Area Networks**
- 18. Products not covered by these standards that may require OIT support**
- 19. Definitions of Abbreviations Contained in these Standards**

1. General

1.1. The Office of Information Technology is responsible for providing voice, data and video services for the University of Minnesota. Every effort is being made to keep the rates for these services as low as possible, while still providing service and maintenance in a timely manner. OIT is constantly evaluating emerging technologies and equipment so that we can continue to offer the most reliable, up to date and cost effective services.

1.2. It is essential to design the telecommunications systems to meet present and future voice and data communication needs. Horizontal and vertical wiring and the pathways and communication rooms should be considered an integral part of the building infrastructure and therefore capable of future growth as new technology and customer needs change. Voice and data projects that are released for bid should be bid separately from and not included with security, audiovisual, building control systems or other equipment or materials that are not directly associated with the independent high speed data or voice communications system. Refer to the OIT Web page at www1.umn.edu/nts/wiring3.shtml for the most recent revision of these standards. The standards herein apply to the technologies in use at the time of the latest update to these standards. The implementation of newer technologies shall require adherence to the standards written at the time of that implementation.

1.3. Telecommunications systems include vertical and horizontal copper and fiber optic wiring and associated termination hardware on both ends. The system includes pathways and conduits; equipment racks; frames wire management systems; communication rooms; and the electrical, mechanical and environmental equipment required to support them. It is essential that OIT shall be consulted prior to and throughout the design process to ensure present and future voice and data services can be met. The space and facilities in this specification are designed to meet the telecommunications requirements (voice and data networking) only for university buildings. These specifications are intended to allow OIT to meet the telecommunications requirements of the university over the lifetime of the buildings. Where ambiguity or questions arise to specific details not mentioned in these standards, appropriate EIA/TIA, NEC and BICSI standards shall apply. OIT **MUST** provide prior written approval for any deviations from these standards. All applicable building codes must be strictly adhered to in regards to telecommunications services. OIT cannot waive building codes.

1.4. A BICSI-certified Registered Communications Distribution Designer (RCDD) shall design, engineer and sign off on all projects. A minimum of 25 percent of the installers and technicians who are installing the horizontal and vertical wiring systems and the connecting hardware shall be BICSI-certified or NECA-certified. The on-site foreman shall be a BICSI-certified RCDD. RCDDs, technicians and installers shall be certified by the manufacturer of all equipment that they will be installing or maintaining.

(LINK 1. GENERAL HERE TO DIVISION 16 A. GENERAL, ELECTRICAL DRAWINGS)

2. Special Requirements

2.1. University of Minnesota buildings frequently contain special purpose facilities and equipment with unique telecommunications requirements. OIT needs to be notified of these special requirements as early in the design process as possible. Special telecommunications requirements may require deviation from this specification.

2.2. The following is a short list, but not all-inclusive, of facilities and equipment which commonly have special telecommunications requirements:

- A. Data centers or computer rooms
- B. Computer labs or classrooms
- C. Video conferencing rooms
- D. Laboratories
- E. Medical imaging equipment
- F. Scientific equipment
- G. Public telephones
- H. Internet kiosks
- I. Wireless networking

3. Entrance Facilities: OIT shall designate the shortest practical route for the communications cable to connect from the building to the point of connection with the university telephone cable system.

Conduit shall be installed within the facility from the point of entry to the telecommunications main equipment room. Diverse facilities entrances are required for all new buildings that will house voice and data equipment that OIT or the end-user considers to be essential for university business continuation. OIT shall be consulted prior to design to consider diverse facility entrances. In the event that diverse cable facility entrances are not deemed necessary, provisions shall be made for four, 4-inch conduits for access from the university cable system to the telecommunications main equipment room. Each of these conduits must be labeled TEL MDF ONLY. Adhere to all BICSI requirements in Chapter 9 of the Telecommunications Distributions Methods Manual (TDMM), Ninth edition or subsequent releases. OIT must approve of any deviations from the BICSI TDMM.

4. General Telecommunications Rooms Requirements

4.1. PROHIBITED: Locating other non-OIT resources in telecommunications rooms.

4.2. PROHIBITED: Using telecommunications rooms as a route for other facilities to pass through.

4.3. PROHIBITED: Using boiler rooms, air exchange rooms, janitorial closets, electrical distribution closets or areas with water heaters and wet sinks for communications. It is essential that these spaces be dedicated to telecommunications.

4.4. Telecommunications rooms are special-purpose rooms that house telecommunications equipment and wiring. These rooms have specific requirements due to the nature, size and complexity of the equipment and wiring housed in these rooms.

4.5. There may be up to three types of telecommunications rooms within a building, each supporting critical functions as part of the building wiring and telecommunications systems. In general, each room must be large enough to accommodate the wiring and equipment that will be located within them, plus additional space for growth over the lifetime of the building. The three types of rooms are:

- A. Main equipment room
- B. Communications rooms
- C. Terminal space/satellite rooms

4.6. All of the main, communications and terminal/satellite rooms shall have a ground buss and meet all requirements of ANSI/TIA/EIA-607 Commercial Building Grounding and Bonding Requirements, NEC Article 800 and Article 250 and Chapter 17 of BICSI TDMM, Ninth edition or subsequent releases.

4.7. Fire suppression systems for all of these rooms shall be two-stage water systems; no Halon or gas systems. Pipes must be insulated to prevent water condensation from forming, and possibly damaging telecommunications equipment. Fire suppression system pipes shall not be installed directly over equipment, but rather placed near the walls with the manifold pipes in ceiling corners.

4.8. All penetrations into fire walls, conduits, sleeves through floors and cable trays that pass through a fire-rated wall must be properly fire-stopped in accordance with the National Fire Protection Association (NFPA), ANSI/NFPA-70 NEC, Article 300-21, EIA/TIA-569 and Chapter 15 of BICSI TDMM, Ninth edition or subsequent release. The manufacturer's recommended installation practices must be followed. Each installation of fire-stopping material must only be used in applications as specified by the fire-stop manufacturer. Fire-stopping pillows also are acceptable to seal an opening that may need to be re-entered at a later time. Any fire-stopping material that is removed to install additional cable must be replaced upon completion.

5. Main Equipment Room

5.1. The main equipment room is the main room in a building into which all outside facilities are routed to and terminate. This room serves as the primary telecommunications room, and may house the PBX equipment and/or backbone network-related electronic equipment. All communications rooms are then fed from the main equipment room. Main equipment rooms and communications rooms shall be located in common building areas that are readily accessible. Main equipment facilities shall be installed in a separate and secure room specifically intended for this purpose. This area shall be free from possible high ambient temperature, excessive humidity, possible dripping pipes, dirt and flooding. The main equipment room must be well ventilated and environmentally controlled 24 hours a day, seven days per week. The main room also must maintain a positive pressure with a minimum of one air change per hour. It must maintain a heat dissipation rating of 225 BTUs per square foot and maintain a constant temperature between 64 degrees F and 75 degrees F with a relative humidity range between 30 percent and 55 percent.

5.2. The size and location of this area shall be determined in feet with a minimum room size of 400 square feet and no dimension smaller than 20 feet. All walls shall be covered with 8 feet by 4-foot wide by 3/4-inch thick unpainted fire-retardant CD grade or better plywood backboard, mounted with the smooth side out from the floor to a minimum height of 8 feet. The minimum ceiling height shall be 8 feet by 6 inches. Doors shall be a minimum of 3-feet wide and 6 feet by 8 feet high. The room number shall be designated on the door or outside wall. Refer to BICSI TDMM, 2000, Ninth edition, Chapter 8 or subsequent releases for additional information on room area based on useable building floor area.

5.3. Main equipment rooms must have drainage capabilities, and be equipped with a one-way drain.

5.4. Working clearances around electrical equipment shall adhere to NEC Section 110-16. One 120-volt AC dedicated duplex receptacle shall be provided for every 6 linear feet of floor perimeter. No more than three receptacles shall be dedicated per branch circuit. Installation of these receptacles shall be in consultation with OIT.

5.5. A main grounding buss bar shall be provided and attached to an approved building ground as per NEC 250-50. Main equipment rooms shall be equipped with OIT U-Card access. When a main equipment room is to be used as a PBX equipment room, it must have a minimum of two

redundant air conditioners. The air conditioners cannot be dependent on the same supporting equipment such as a chiller, piping, motors and power breakers. Each air conditioner must be able to support the room on its own and must be sized 50 percent larger than the BTU rating of the total installed equipment. The unit must cycle on and off at a 50 percent rate.

5.6. The power feed to the UPS systems must be included in the building generator distribution system and appropriate transfer switches installed. If no generator is provided, emergency generator planning must be completed. This may include OIT placing a generator on-site or an emergency power coupler installed in a location that is accessible by OIT portable generators. Full-circuit documentation must be provided prior to starting up the switch room. A battery backup system located in a separate room specifically designed for that purpose might also be required. Where there is battery backup in rooms, they must include the required Occupational Safety and Health Administration (OSHA) containment system for sealed and spill-proof batteries. Environmental alarms must meet state, federal and university codes and be interfaced to OIT card access/alarm panels. Panels would include all UPS alarms, generator active alarms, fire, temperature, humidity, A/C unit transition switch, floor water detection, battery damper and door breach. Refer to Section 16 of this appendix for additional information on power requirements.

5.7. The main equipment room shall serve as the primary copper and fiber-optic cable distribution center for the building. All voice and most data distribution shall emanate from this room. OIT must pre-approve a Panduit Opticom HD High Density Fiber Distribution System or equivalent to be used in this room to accommodate the fiber-optic cabling. Fiber optic cabinets shall be Panduit HDFE Series or prior OIT-approved substitute. OIT must pre-approve a Homaco 110D9000 copper frame or equivalent to be used in this room to accommodate the copper cabling. Any questions regarding part numbers for these frames should be referred to OIT.

5.8. Because building requirements vary, consultation with OIT prior to finalizing building plans is essential.

6. Communications Rooms

6.1. Riser facilities shall be installed in communications rooms, which are separate, and secure rooms specifically intended for this purpose and intended for exclusive use by OIT. Riser cables shall be distributed in one or more riser shafts enclosed in a series of vertically aligned closets beginning in the basement and extending throughout the height of the building. These shafts shall be aligned vertically to facilitate cable pulling.

6.2. The general requirements for communications rooms are:

6.2.1. PROHIBITED: False ceilings installed in communications rooms.

6.2.2. Six conduits of 4-inch size or 24-inch cable tray for exclusive OIT use shall be placed between the main equipment room and the bottom riser room. Each of these conduits must be labeled TELE RISER ONLY.

6.2.3. Communications rooms shall be interconnected by 4-inch sleeves that extend a minimum of 2 inches to a maximum of 3 inches above the floor with bushings and fire stop. The sleeves shall be for exclusive use by OIT, and each of these sleeves must be labeled TELE RISER ONLY. The sleeves shall be located at the left edge of the terminal board, as close to the wall as possible. Sleeves shall never be placed in the center of the terminal board. At least six interconnecting conduits or sleeves shall be provided. If closets cannot be aligned vertically, six conduits of 4-inch size or 4-inch by 24-inch cable tray shall be placed between them for exclusive OIT use. All conduits and sleeves must be labeled TELE RISER ONLY.

6.2.4. The minimum size for a communications room is 100 square feet and the dimensions for this room are 10 feet by 10 feet with no dimension shorter than 6 feet. To determine proper size of communications rooms, refer to BICSI, Ninth edition, Chapter 7 or subsequent releases, and consult with OIT during the design phase.

6.2.5. The communications rooms must have adequate ventilation, and be environmentally controlled 24 hours per day, seven days per week. The rooms shall maintain a positive pressure with a minimum of one air change per hour, as well as maintain heat dissipation rating of 48 BTUs per square foot. The rooms also must maintain a constant temperature between 64 degrees F and 75 degrees F, with a relative humidity between 30 percent and 55 percent.

6.2.6. The door on the communications room shall be 3 feet wide or wider, with a minimum height of 6 feet, 8 inches, and be equipped with a TR key core or with OIT U Card access.

6.2.7. The room number shall be designated on the door or outside wall.

6.2.8. All walls must be covered with 4-foot by 8-foot wide by 3/4-inch thick unpainted fire-retardant CD grade or better plywood backboard, mounted with the smooth side out from the floor to a minimum height of 8 feet.

6.2.9. Provide overhead lighting with a minimum of 50 foot-candles measured at 1 meter from the floor. Also provide a convenience switch at room entry.

6.2.10. The minimum ceiling height shall be 8 feet, 6 inches. Clearance shall be specified per NEC 110-16.

6.2.11. One 120-volt AC dedicated duplex receptacle shall be provided for every 6 linear feet of floor perimeter. No more than three receptacles shall be dedicated per branch circuit. Installation of these receptacles shall be in consultation with OIT. Electrical outlets shall be placed above the top edge of the plywood sheet.

6.2.12. The termination for station cabling shall be labeled with the corresponding jack number in accordance with the jack-labeling scheme as outlined in Section J of this appendix.

6.2.13. OIT recommends that all floor penetrations be sleeved for the following reasons:

- A. Ease of fire-stopping
- B. Prevent water from leaking and spilling to lower floors
- C. Prevent cables being installed between floors from chaffing

7. Terminal Space/Satellite Rooms

7.1. Terminal space/satellite rooms are communication facility spaces that are connected to a communication room used for riser distribution, and do not connect directly back to the equipment rooms.

7.2. The general requirements for telecommunication spaces are:

7.2.1. PROHIBITED: False ceilings installed in terminal rooms.

7.2.2. Terminal spaces/satellite rooms shall be installed in a separate and secure area. These rooms are designed exclusively for OIT use.

7.2.3. Use 4-foot wide by 8-foot wide by 3/4-inch thick unpainted fire-retardant CD grade or better plywood backboard mounted with the smooth side out and along all walls of the closet from the floor to a minimum height of 8 feet.

7.2.4. Include overhead lighting with a minimum of 50 foot-candles measured at 1 meter from the floor. Also include a convenience switch at room entry.

7.2.5. Terminal space shall be no more than 80 meters from the center of the room to the center of the nearest communications room. Connections from the communications room to the terminal facilities shall adhere to the raceway specifications. Refer to Section 8 - Raceway/Tray Systems.

7.2.6. The minimum size for terminal rooms shall be 10 feet by 8 feet. Refer to Chapter 7, BICSI TDMM, Ninth edition or subsequent releases. No dimension shall be less than 5 feet. Minimum ceiling height shall be 8 feet, 6 inches. Clearance shall be specified per NEC section 110-16.

7.2.7. Provide space ventilation or air conditioning to maintain recommended operating temperature and humidity levels for the equipment. Refer to BICSI TDMM, Ninth edition, Chapter 7 or subsequent releases. The terminal room must be well ventilated, and environmentally controlled for 24 hours per day, seven days per week. Maintain a positive pressure with a minimum of one air change per hour, and maintain heat dissipation rating of 60 BTUs per square foot. The terminal room must maintain a

constant temperature between 64 degrees F and 75 degrees F with a relative humidity between 30 percent and 55 percent.

7.2.8. One 120-volt AC dedicated duplex receptacle shall be provided for every 6 linear feet of floor perimeter. No more than three receptacles shall be dedicated per branch circuit. Installation of these receptacles shall be in consultation with OIT. Electrical outlets shall be placed at the top of each plywood sheet.

7.2.9. Terminal facilities shall be equipped with access via a TR key.

7.2.10. The termination for station cabling shall be labeled with the corresponding jack number in accordance with the jack-labeling scheme as outlined in Section 10 of this appendix.

7.2.11. The room number shall be designated on the door or outside wall.

7.2.12. OIT recommends that all floor penetrations be sleeved for the following reasons:

- A. Ease of fire-stopping
- B. Prevent water from leaking and spilling to lower floors
- C. Prevent cables being installed between floors from chaffing

8. Raceway/Tray Systems

8.1. The general requirements for raceway/tray systems are as follows:

8.1.1. The systems shall be designed for no more than 40 percent fill.

8.1.2. The systems must be metallic and continuous with all separate pieces bonded where they are joined.

8.1.3. The systems must be grounded to the building grounding system with a minimum 6 AWG copper conductor.

8.1.4. Use insulated metallic bushings for attached metallic conduits. Ground and bond the conduits to the tray as illustrated in Figure A.

8.1.5. The tray shall be ladder or wire basket style.

8.1.5.1. The ladder style tray shall have a rail on each side, and shall have the rungs enclosed and welded in place.

8.1.5.2. A wire basket tray shall be U shaped and constructed of round wire mesh. The basket tray shall be hung via the trapeze style or wall-mounted. It must not be center hung.

8.1.6. Use end-of-tray cable waterfalls where wire drops down to prevent abrasions and cuts from metal tray edges.

8.1.7. The tray must be no closer than 6 inches from the structural ceiling, ducts or pipes, or all other possible obstructions. The tray also is required to be a minimum of 5 inches from lighting, especially fluorescent lighting.

8.1.8. The complete cable tray must meet OIT approval.

8.2. Compliance to this standard requires fulfillment of each of the following:

8.2.1. The end of rigid or flex conduit must:

- A. Have a bushing
- B. Lie within the side and end planes of the cable tray
- C. Lie within the tolerated distance as illustrated
- D. Be anchored to a rigid support
- E. Be grounded and bonded to the cable tray with a minimum #14 AWG copper conductor

8.3. NEC Article 100 and Section 250-70 defines bonding as: "The permanent joining of metallic parts to form an electrically conductive path which will assure electrical continuity and the capacity to conduct safely any current that is likely to be imposed."

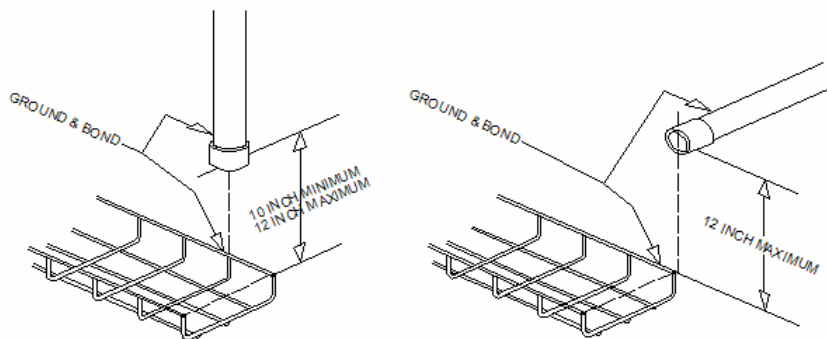

Figure A: Conduit to Cable Tray Configurations.

The image on the left is a vertical conduit configuration. The image on the right is a horizontal conduit configuration.

9. Outlet Facilities

9.1. PROHIBITED: Daisy chaining of conduit.

9.2. PROHIBITED: Splitting copper pairs between jacks. TIA/EIA-568-B-1 states: "Each 4-pair cable shall be terminated in an eight-position modular jack at the work area."

9.3. PROHIBITED: Sharing the outlet and conduit pathway.

9.4. PROHIBITED: Using traditional nylon synch style tie wraps to bundle cables. Only Velcro style tie wraps are acceptable.

9.5. Telecommunications outlets shall be wired with unshielded, twisted pair 24 AWG wire (UTP) with suitable insulation and sheath material to meet or exceed EIA/TIA 568B.2 or equivalent. The wire shall be type communications riser cable (CMR) or communications plenum cable (CMR) (UL) with rating dependent or NEC Section 800-15, and OIT approved.

9.6. The current position of OIT on horizontal cabling is to recommend the installation of Category 5E cable. Because of the variety of infrastructure on campus, OIT cannot guarantee performance without an upgrade of the infrastructure to support higher bandwidth requirements of new technology. For example, installing Category 6 cabling does not guarantee performance at increased bandwidths without an upgrade of the installed infrastructure/backbone system.

9.7. If a building initially is wired with Category 6 cabling, any subsequent wiring shall be done exclusively with Category 6 cable. Deviation of wiring levels when the original is installed with Category 6 is not recommended unless OIT pre-approves in advance in writing. Any movement, additions or changes after the initial installation shall require Category 6 cable to be used. One manufacturer's brand shall be used for each component type throughout a building if the Category 6 wiring system requires the same vendor products in order to retain Category 6 standards and successful testing.

9.8. The general requirements for outlet facilities include the following:

9.8.1. Telecommunication outlets shall be 4-inch by 4-inch by 2-1/2 inch boxes with a minimum 1-inch ID continuous metallic conduit provided to the nearest terminal or ceiling raceway system. Refer to Section 8 for raceway/tray system requirements. Each conduit shall be installed in a home-run configuration.

9.8.2. Conduits shall be placed in the straightest run possible with no more than the equivalent of two 90° bends per run.

9.8.3. Refer to BICSI TDMM, Ninth edition, Chapter 4 or subsequent releases for information on conduit sizing and routing.

9.8.4. Jacks shall be mounted in Panduit product number CF1064EI, Avaya product number M106FR4-246 mounting frame (Ivory) or prior OIT-approved substitute.

9.8.5. All wall outlet boxes shall be equipped with two-gang cover plates. Only the following outlets shall be equipped with the a one-gang cover plate:

- A. Outlets designated for wall telephones
- B. Outlets designated for pay telephones

9.8.6. Two co-located 4-inch by 4-inch by 2-1/2-inch boxes shall be provided with terminations. Distribution of fiber/copper between the two boxes shall be in consultation with OIT. The boxes shall be adjacent, but separated by a minimum of 12 inches.

9.8.7. Conduit sizes shall be adequate for the cable needed to serve voice and data instruments. The minimum size for conduit is 1 inch.

9.8.8. A minimum of 12 inches of slack for Cat 5E copper and 1 meter of fiber shall be left in each outlet. For Cat 6 cable, 12 inches of slack for each outlet is required, however, the slack cannot remain in the box behind the outlet. The slack must be loosely coiled and remain in the cable tray. For homerun conduits, the slack must remain in the communications/terminal rooms.

9.8.9. The number of wires or fiber strands terminated to each communication outlet shall be determined in consultation with OIT. OIT recommends a minimum of four Category 5E cables at each copper outlet: two for voice and two for data.

9.8.10. Each copper outlet shall contain the following jacks:

9.8.10.1. Voice jacks

A. Category 5E

1. Panduit product code number CJ5E88TIG (gray)
2. Avaya product code number MPS100E-270 (gray) or prior OIT-approved substitute

B. Category 6: Panduit product code number CJ688T3IG (gray) or prior OIT-approved substitute

9.8.10.2. Data jacks

A. Category 5E

1. Panduit product code number CJ5E88TBOR (orange)
2. Avaya product code number MPS100E-112 (orange) or prior OIT-approved substitute

B. Category 6: Panduit product code number CJ688T3OR (orange) or prior OIT-approved substitute

9.8.11. Category 3 and Category 5 cables are no longer recommended for installation.

9.8.12. Recommended copper cabling specifications are as follows:

9.8.12.1. Blue Cat5E plenum

- A. Avaya product code 106946825
- B. Berktech product code 230645
- C. General product code 6131433
- D. Mohawk product code M56168

9.8.12.2. Blue Cat5E PVC

- A. Avaya product code 107251636
- B. Berktech product code 530529
- C. General product code 6133403
- D. Mohawk product code M56167

9.8.12.3. Green Cat6 plenum

- A. Berktech product code 230722
- B. General product code 7131649
- C. Mohawk product code M57197

9.8.12.4. Green Cat6 PVC

- A. Berktech product code 530661
- B. General product code 7133512
- C. Mohawk product code M57206

Note: Avaya copper cable only shall be used for projects that have Avaya jacks and connectors. Avaya does not warranty the installation unless the company manufactured all of the components.

9.8.13. All copper wiring and connectors must conform to the following specifications:

- A. Category 5E: ANSI/TIA/EIA 568-B-2
- B. Category 6: ANSI/TIA/EIA 568-B-2, TSB-36, TSB-40A, NEMA 100-24-XF, UL Level IV

9.8.14. Wire shall meet or exceed EIA/TIA 568B-2 Category 5E and NEMA low loss extended frequency requirements.

9.8.15. The amount of slack in the terminal room from the jack location shall be decided in consultation with OIT.

9.8.16. Each cable in the terminal room from the jack shall be tagged with the current designation from the current architectural drawings.

9.8.17. Station cabling shall be terminated to the standards and specifications required for that particular category of cable.

9.8.18. Station cables shall be terminated in order according to jack number wherever and whenever possible. Refer to Section 10 for more information on the outlet-labeling scheme.

9.8.19. Wire each jack configuration designation according to EIA/TIA spec 568-B (Designation T568B).

9.8.20. All copper and fiber cable must be continuously supported by conduit or cable tray.

9.8.21. All Category 5E and Category 6 installations also must conform to the component configurations and installation practices contained in EIA/TIA 568-B.

9.8.22. Fiber optic cables shall comply with EIA/TIA-568-B and performance measurements of EIA/TIA-455-46, -61 or -53.

9.8.23. The jack cover plate shall be 302 stainless steel or other OIT-approved cover or housing.

9.8.24. Standard telecommunications outlets shall be installed at a minimum of 15 inches above a finished floor and at the same height as the electrical outlets as specified in Division 16. Standard telecommunications outlets for wall phones shall be 48 inches above a finished floor. All measurements are from the floor to the center of the outlet.

9.8.25. Floor-mounted outlets used for modular furniture shall be a Walker RCI RC3 flush poke-through unit, with Panduit 2 position adapter CRC3A2BL-X or dual Avaya (AT&T) 2A-U2ATT or prior OIT-approved substitute.

9.8.26. Accessible phone outlets for people with disabilities shall be:

- A. 48 inches to the highest operable mechanism for forward reach
- B. 54 inches to the highest operable mechanism for side reach
- C. All other outlet facilities specifications for people with disabilities shall be compliant with CABO/ANSI A117.1 standards.

9.8.27. Telecommunications outlets shall not be placed in a back-to-back location, but shall be separated by a minimum of 12 inches. Telecommunications outlets in fire-rated walls shall be separated by 24 inches.

9.8.28. Telecommunications outlet boxes shall be used solely for low-voltage wiring for telecommunications.

9.8.29. Refer to Section 11 for communications/terminal room termination requirements.

10. OIT Outlet Labeling Scheme: Each jack location in an outlet facility shall be labeled in accordance with OIT jack-labeling practices. The labeling follows a standard format indicating the room followed by the location within the room. For example, if the jack-labeling were 00100-AA:

10.1. 00100 denotes the room number in which the jack is installed. Hence each jack within Room 100 shall have this prefix.

10.2. This prefix field is always five digits.

10.3. AA is a two-character code denoting in sequence the count of the jack installed (that is, AA for the first jack installed, AB for the second jack installed and so on). Hence, the second jack installed (possibly within the same outlet box) in Room 100 would be labeled as 00100-AB.

10.4. Rooms within a larger room may be designated as Room 100A, and may be labeled as 0100A-AA. For larger rooms it may be necessary to continue the labeling sequence beyond AZ so that the next installed jack would be labeled BA, BB and so on, and if necessary, continued throughout the alphabet (CA, CB and so on).

10.5. The room numbers appearing on the architect blueprints shall be used to determine the labeling. For this reason, room numbers shall not change due to the extensive labor involved in re-labeling each jack location and changing it in its associated database.

10.6. Jacks must be neatly labeled with a printed self-adhesive label that OIT must approve in advance. The labels must be typed/printed, and are not to be drawn by hand.

10.7. As Built drawings that show jack numbers and locations shall be submitted to OIT upon completion of the project/building.

11. Communications/Terminal Room Termination Requirements

11.1. All new construction shall use Category 6 patch panels for data, and Category 6 rated 110 punch blocks for telephone. Category 5E installations shall terminate both voice and data on 110 style punch blocks. (See Figure B.)

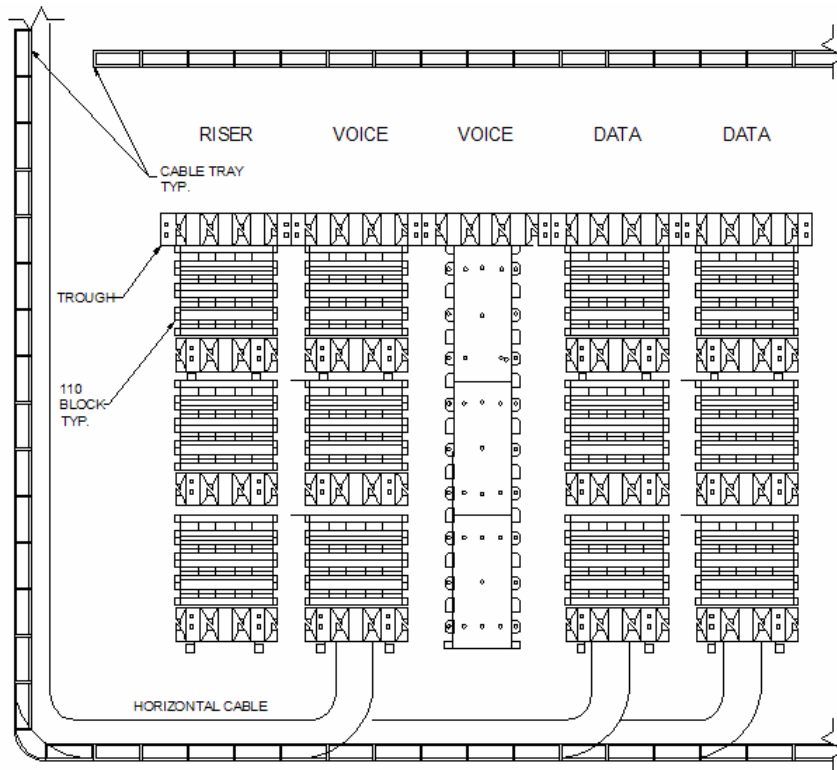

Figure B: Typical Backboard Layout

11.2. The general requirements for wall termination of copper cabling are as follows:

11.2.1. Provide 110 IDC systems mounted to the 4-foot by 8-foot by 3/4-inch unpainted fire-retardant CD grade or better plywood backboard that is mounted with the smooth side out.

11.2.2. Install terminal blocks vertically plumb and securely fastened to the plywood backboards. Install top jumper trough 2 feet down from the top of the plywood.

11.2.3. Install a 12-inch wire basket style tray at the top of the plywood for the length of the termination field. Install a 12-inch wire basket style tray 8 inches below the bottom of the lowest jumper trough. Refer to Figure B. This tray must be bonded and be attached to the ground buss and meet all of the requirements of ANSI/TIA/EIA-607 Commercial Building Grounding and Bonding Requirements, NEC Article 800 and Article 250, and Chapter 17 of BICSI TDM, Ninth edition or subsequent releases.

11.2.4. Install cables without violating the minimum bend radius that the cable manufacturer recommends. Route station cables in brackets, troughs and wire ways that are specifically designed for Cat 5E/Cat 6 applications. Fasten cables securely with Velcro style tie wraps to prevent strain at the terminations.

11.2.5. Recommended wall-mounted copper connectivity specifications are as follows:

11.2.5.1. Cat 5E

- A. Panduit 5E 110 Connecting Block P110B100-X
- B. Panduit Jumper Trough w/o legs P110JT-X
- C. Seltek 110 Cable Guide (backchannel) CG300

11.2.5.2. Cat 6

- A. Panduit Giga-punch 110 Connecting Block GPB144-X
- B. Panduit Jumper Trough w/o legs P110JT-X
- C. Seltek 110 Cable Guide (backchannel) CG300

11.3. The general requirements for equipment racks are as follows:

11.3.1. They shall be of steel construction that is self-supported and floor-mounted.

11.3.2. Securely mount the racks to the floor using expansion anchors.

11.3.3. They must have cable management with vertical channels, and pass through holes and slots for additional cable management accessories.

11.3.4. Wire management must accept removable, hinged doors.

11.3.5. Include movable, plastic D rings for flexible cable management.

11.3.6. Meet all EIA requirements as defined in EIA-310-D.

11.3.7. The racks shall have a Panduit CMRSW84 Rack System or prior OIT-approved substitute.

11.3.8. Provide a horizontal 12-inch wire basket style tray that is mounted above all equipment racks. The tray must be properly bonded and grounded.

11.3.9. Allow for a minimum of two equipment racks per room.

11.3.10. All equipment racks shall be grounded to the ground buss and meet all of the requirements of ANSI/TIA/EIA-607 Commercial Building Grounding and Bonding Requirements, NEC Article 800 and Article 250, and Chapter 17 of the BICSI TDMM, Ninth edition or subsequent releases.

11.4. The general requirements for patch panels are as follows:

11.4.1. Category 5E/Category 6 patch panels shall consist of EIA-approved 19-inch patch panels with optional extensions to fit a 23-inch rack.

11.4.2. Panels must accommodate 24 jacks per 1-1/2 inch rack space.

11.4.3. The eight-pin modular jack must be able to be removed from the front or from the rear of the panel.

11.4.4. Individual jacks must be replaceable without causing any interruption of service to any other jack.

11.4.5. The eight-pin modular jack must provide proper strain relief by encompassing the insulation of the cable within the back of the jack.

11.4.6. Panels shall be UL 1863 listed black in color.

11.4.7. A labeling area shall be installed on the front for jack identification.

11.4.8. Patch panels shall be a Panduit product CPP series or prior OIT-approved substitute.

11.5. The general requirements for horizontal management are as follows:

11.5.1. Design to support Category 5E/Category 6 cables without compressing or causing a kink in the cables.

11.5.2. Horizontal cable management panels must be included on the racks and shall have an EIA-compliant 19-inch wiring management duct that is one rack space tall (with optional extensions to fit a 23-inch-wide rack).

11.5.3. A wire management panel must be placed above the first patch panel, every third rack space thereafter, and below the last patch panel.

11.5.4. The wire management panel shall have a 1-1/2 inch by 2-inch front wire management duct, and a 1-inch by 4-inch rear wire management duct.

11.5.5. Covers for each duct shall be removable/hinged.

11.5.6. The entire panel shall be black.

11.5.7. Specify Panduit product code number NCMH1 or prior OIT-approved substitute.

11.5.8. Consult with OIT in regards to the needs and design of vertical wire management ducts.

11.6. The general requirements for fiber-optic rack-mounted enclosures are as follows:

11.6.1. Fiber-optic rack-mounted enclosures shall consist of an EIA-approved 19-inch enclosure (with optional extensions to fit in a 23-inch rack), four spaces tall (7 inches) with a minimum capacity of 72 duplex ports.

11.6.2. Individual fiber jacks must be removable from the front or from the rear of the panel.

11.6.3. Jacks must be removable without causing any interruption of service to other jacks.

11.6.4. Dust covers must be provided for any unused jacks in each enclosure.

11.6.5. The enclosure shall be black.

11.6.6. Specify Panduit product FRME-enhanced series or prior OIT-approved substitute.

12. Fiber Optic Cable

12.1. Fiber optics shall be 62.5 mm and 125 um to meet or exceed ANSI/EIA/TIA-492 AAAA. Each strand of fiber must be housed in its own buffer tube throughout the length of the fiber cable. Each cable in the terminal room from the jack shall be tagged with the current designation from the current architectural drawings. Consult with OIT to determine the amount of slack in the terminal room from the location of the jack.

12.2. Recommended fiber specifications are as follows:

A. Multi-mode plenum

1. BerkTek product number ICP002CB3510/55
2. General product number CT0021PNU

B. Multi-mode PVC

1. BerkTek product number ICR002CB3510/55
2. General product number CT0021PNR

C. Single-mode plenum

1. BerkTek product number ICP0X0AB0707
2. General product number AP0021PNR

3. Siecor product number 002R88-31131-29

D. Single-mode PVC

1. BerkTek product number ICR0X0AB0707
2. General product number AP0021PNR
3. Siecor product number 002R81-31131-24

Due to technological advances and changes in vendors' part numbers, please refer to the online version of these standards (<http://www1.umn.edu/nts/wiring3.shtml>) for updated part numbers.

13. Small Form/Modular Style Fiber Standards

13.1. All small form multi-mode modular style duplex fiber connectors must meet or exceed TIA 455 and ISO/IEC 874-1 performance specifications as indicated in Figure C.

Figure C

TIA 455	ISO/IEC 874-1	Description	Test Procedure and Required Performance
1	-----	Flex	Apply 1.1lb load through 180° for 100 cycles; <0.3dB additional loss
2	4.5.11	Impact	Drop 8 times from 8ft (2.46m), 8 times from 6ft (1.82m); <0.3dB additional loss
3	4.5.2.2	Thermal Cycling	-40°C to +65°C for 5 cycles; <0.3dB additional loss
4	4.5.18	High Temperature	70°C for 14 days; <0.3dB additional loss <0.14dB additional loss
5	4.4.19	Humidity	55° at 95% RH for 4 days; <0.3dB additional loss
6	4.5.4	Cable Retention	Apply 15lb. load for 5 seconds, 0° angle;<0.3dB additional loss
11	4.5.1	Vibration	Vibration 10-55Hz, 2 hours each axis; <0.3dB additional loss
13	4.4.1.2	Visual, Mechanical	Inspection and mechanical dimensions FOCIS-6 compliant
21	4.5.32	Durability	Mate/unmate connectors (500 cycles) <0.3dB additional loss
34	4.4.7	Insertion Loss	Test insertion loss using cut-back method; 0.75dB maximum loss
36	4.5.5	Twist	Apply 3.3lb load, 10 cycles from +90° to -90°; <0.3dB additional loss
71	4.5.22	Temperature Shock	40 cycles from -20°C to +65°C; <0.3dB additional loss
185	4.5.6	Coupling Strength	Pull plug from jack, 25lb load for 60 seconds; <0.3dB additional loss, 0.75dB maximum loss
188	4.5.17	Low Temperature	-25°C for 4 days; <0.3dB additional loss

13.2. All small form single-mode modular style duplex fiber connectors must meet or exceed TIA 455, ISO/IEC 874-1, and Bellcore 326-CORE performance specifications as indicated in Figure D.

Figure D

TIA 455	ISO/IEC 874-1	Bellcore 326-CORE	Description	Test Procedure and Required Performance
1	--	4.4.3.2	Flex	Apply 1.1lb load through 180° for 100 cycles; 0.75dB max insertion loss, 26dB min return loss
2	4.5.11	4.4.3.7	Impact	Drop 8 times from 6ft (1.82m); <0.75dB max insertion loss, 26dB min return loss
4	4.5.18	4.4.2.1	High Temperature	55°C for 14 days; <0.3dB additional loss 0.75dB max insertion loss, 26dB min return loss
5	4.5.19	4.4.2.3	Humidity	40° at 95% RH for 4 days; <0.4dB additional loss 0.75dB max insertion loss, 26dB min return loss
6	4.5.4	4.4.3.4	Cable Retention	Apply 15lb load for 5 seconds, 0° angle; 4.4lb at 90° <0.5dB additional loss 0.75dB max insertion loss, 26dB min return loss
13	4.4.1,2	3.4,3.5	Visual, Mechanical	Inspection and mechanical dimensions
21	4.5.32	4.4.3.8	Durability	Mate/unmate connectors (500 cycles) <0.75dB max insertion loss, 26dB min return loss
34	4.4.7	4.4	Insertion Loss	0.75dB max insertion loss
36	4.5.5	4.4.3.3	Twist	Apply 3.4lb load, 10 cycles from +90° to -90°; 0.75dB max insertion loss, 26dB min return loss
107	--	--	Return Loss	26dB minimum return loss
185	4.5.6	--	Coupling Strength	Pull plug from jack, 7.4lb load for 5 seconds at 0°; 0.75dB max insertion loss, 26dB min return loss
188	4.5.17	--	Low Temperature	0°C for 4 days; <0.3dB additional loss 0.75dB max insertion loss, 26dB min return loss

13.3. The manufacturer shall have an EIA/TIA Fiber Optic Connector Intermateability Standard (FOCIS) document. It is a component standard written for manufacturers to follow to ensure that their connectors will be intermateable with other connectors of the same type.

13.4. Each small form fiber connector must contain two strands of fiber that meet or exceed the single-mode or multi-mode performance standards specified in this document.

13.5. Each fiber shall be housed in its own separate ferrule within the jack.

13.6. The jack must have separate alignment sleeves for each ferrule.

13.7. The small form fiber jack shall fit into the same manufacturer's flush faceplate that accommodates its copper jacks, so that any combination of two, four or six outlets of copper or fiber cables may be used at any location.

13.8. Small form factor plugs/jacks shall accommodate either single-mode or multi-mode fiber strands.

13.9. Both single-mode and multi-mode jack and plug shall be able to be field terminated.

13.10. High-density fiber jack multi-mode Panduit product number FJJGM5CEI (Electrical Ivory), Avaya product number P1001A-Z-125 shall be used or prior OIT-approved substitute.

13.11. High-density fiber jack single-mode Panduit product number FJJGS9CBU, Avaya product number P1101A-Z-125 shall be used or prior OIT-approved substitute.

14. Testing

14.1. Category 5E

14.1.1. Every cabling link in the installation shall be tested in accordance with ANSI/TIA/EIA-568-B.1.

14.1.2. The horizontal cabling shall be tested from the communications rooms/terminal spaces to the wall outlet using the Permanent Link specification of ANSI/TIA/EIA-568-B.1.

14.1.3. All of the installed cables must be tested and must pass the specifications of ANSI/TIA/EIA-568-B.1.

14.1.4. Any cable that fails shall be terminated and tested again. If the cable does not meet specifications after terminating again, replace the cable, terminate and test again.

14.1.5. The test equipment shall comply with or exceed the accuracy requirements for enhanced Level II (Level II-E) field testers as defined in TIA-568-B, Annex 1, Section 1.4.

14.1.6. The pass or fail condition for the link being tested is determined by the results of the required individual tests. Any fail or fail* result yields failure for the link being tested.

14.1.7. The test results for each link shall be recorded in the memory of the field tester upon completion of the test.

14.1.8. The test results saved by the tester shall be transferred to a CD-ROM. A guarantee must be made that the results of the measurement shall be transferred to the CD-ROM unaltered, that is, as saved by the tester at the end of each test. The guarantee also must specify that the results cannot be modified at a later time.

14.1.9. The test results for the completed job shall be stored and delivered to OIT on a CD-ROM, including the software tools required to view, inspect and print any selection of test reports.

14.1.10. A paper copy of the test results shall be provided to OIT in a three-ring binder. The following summary information shall be included:

- A. The identification of the link in accordance with the OIT labeling scheme
- B. The name of the building where the cable is located
- C. The brand name, model and serial number of the tester
- D. The identification of the tester interface
- E. The revision of the tester software and the revision of the test standards database in the tester
- F. The overall pass/fail evaluation of the link being tested, including the Near End Cross Talk (NEXT) Headroom (overall worst case) number
- G. Date and time the test results were saved in the memory of the tester
- H. The name of the standard selected to execute the stored test results
- I. The type of cable being tested (Cat 5E)
- J. The brand name and model number of the tester

14.1.11. The detailed test results must include the following parameters:

- A. Wire map
- B. Length
- C. Insertion loss
- D. Near-End Cross Talk (NEXT)
- E. Power Sum Near-End Cross Talk (PSNEXT)
- F. Equal-Level Far End Crosstalk (ELFEXT)
- G. Power Sum Equal-Level Far-End Crosstalk (PSELFEXT)
- H. Return loss
- I. Propagation delay
- J. Delay skew

14.2. Category 6

14.2.1. Every Category 6 cable in the installation shall be tested in accordance with the field test specifications defined in the most recent draft of the "Transmission Performance Specifications for 4-pair 100 Category 6 Cabling" under development by the TIA. At the time of publication of the 2002 Standards and Procedures for Construction, PN 3727 TIA/EIA Draft Standard - Draft 11B represents the most recent version. Within these standards, this specification shall be referred to as the TIA Cat 6 Draft Standard.

14.2.2. The horizontal cabling shall be tested from the communications rooms/terminal spaces to the wall outlet using the Permanent Link specification in the TIA Cat 6 Draft Standard.

14.2.3. All of the installed cables must be tested and must pass the above-mentioned specification.

14.2.4. Any cable that fails shall be terminated and tested again. If the cable does not meet specifications after terminating again, replace the cable, terminate and test again.

14.2.5. The test equipment shall comply with or exceed the accuracy requirements for the proposed Level III field testers as defined in the TIA Cat 6 Draft Standard.

14.2.6. The pass or fail condition for the link being tested is determined by the results of the required individual tests. Any fail or fail* result yields failure for the link-under-test.

14.2.7. The test results for each link shall be recorded in the memory of the field tester upon completion of the test.

14.2.8. The test results saved by the tester shall be transferred to a CD-ROM. A guarantee must be made that the measurement results are transferred to the CD-ROM unaltered, that is, as saved by the tester at the end of each test. The guarantee also must specify that the results cannot be modified at a later time.

14.2.9. The test results for the completed job shall be stored and delivered to OIT on a CD-ROM, including the software tools required to view, inspect and print any selection of test reports.

14.2.10. A paper copy of the test results shall be provided to OIT in a three-ring binder. The following summary information shall be included:

- A. The identification of the link in accordance with the OIT labeling scheme
- B. The name of the building where the cable is located
- C. The brand name, model and serial number of the tester
- D. The identification of the tester interface
- E. The revision of the tester software and the revision of the test standards database in the tester
- F. The overall pass/fail evaluation of the link tested, including the NEXT Headroom (overall worst case) number
- G. Date and time the test results were saved in the memory of the tester
- H. The name of the standard selected to execute the stored test results
- I. The type of cable being tested (Cat 6)
- J. The brand name and model number of the tester

14.2.11. The detailed test results must include the following parameters:

- A. Wire map
- B. Length
- C. Insertion loss
- D. Near-End Cross Talk (NEXT)
- E. Power Sum Near-End Crosstalk (PSNEXT)
- F. Equal-Level Far End Crosstalk (ELFEXT)
- G. Power Sum Equal-Level Far-End Crosstalk (PSELFEXT)

- H. Return loss
- I. Propagation delay
- J. Delay skew

14.3. Fiber Optic Cable

14.3.1. Every fiber optic cable in the installation shall be tested in accordance with field test specifications as defined in ANSI/TIA/EIA-568-B.

14.3.2. All of the installed fiber optic cables must be tested and must pass the requirements of ANSI/TIA/EIA-568-B.

14.3.3. Any cable that fails these tests must be diagnosed and corrected. The corrective action shall be followed with a new test to prove that the corrected link meets the performance requirements. The final and passing test must be saved and included in the final test results documentation.

14.3.4. Field test instruments for multi-mode fiber cabling shall meet the requirements of ANSI/TIA/EIA-526-14A. The light source shall meet the launch requirements of ANSI/TIA/EIA-455-50B, Method A.

14.3.5. Field test instruments for single-mode fiber cabling shall meet the requirements of ANSI/TIA/EIA-526-7.

14.3.6. The test results for each link shall be recorded in the memory of the field tester upon completion of the test.

14.3.7. The test results saved by the tester shall be transferred to a CD-ROM. A guarantee must be made that the measurement results are transferred to the CD-ROM unaltered, that is, as saved by the tester at the end of each test. The guarantee also must specify that these results cannot be modified at a later time.

14.3.8. The test results for the completed job shall be stored and delivered to OIT on a CD-ROM, including the software tools required to view, inspect and print any selection of test reports.

14.3.9. A paper copy of the test results shall be provided to OIT in a three-ring binder. The following summary information shall be included:

- A. The identification of the link in accordance with the OIT labeling scheme
- B. The name of the building where the cable is located
- C. The brand name, model and serial number of the tester
- D. The revision of the tester software and the revision of the test standards database in the tester
- E. The overall pass/fail evaluation of the link being tested
- F. The name of the standard selected to execute the stored test results

G. Cable type and the value of the index of refraction used to calculate lengths
H. The insertion loss (attenuation) measured at each wavelength, the test limit calculated for the corresponding wavelength and the margin (difference between the measured attenuation and the test limit value)

I. The link length shall be reported for each optical fiber for which the test limit was calculated using the following formulas:

1. Link Attenuation = Cable_Attenuation + Connector_Attenuation = Splice Attenuation

2. Cable_Attenuation (dB) = Attenuation_Coefficient (dB/km) * Length (km)

3. Connector_Attenuation (dB) = number_of_connector_pairs * connector_loss (dB) (Maximum acceptable connector loss = 0.75 dB)

J. The date and time the test results were saved in the memory of the tester

15. Documentation

15.1. Provide complete CAD As Built floor plans in AutoCAD 2000 that contain at least the following information:

- A. Architectural floor plans with finalized room names and numbers
- B. Location and identification of all voice, data and fiber optic outlets
- C. Cable routing. Include a legend on the plans to readily identify the voice, data and fiber optic cables
- D. Conduit sizes and routing for all cables installed in conduit
- E. Cable tray routing and locations
- F. Bonding and grounding locations
- G. Large-scale blowup of all communications/terminal rooms that indicate elevation views and plan views of, including but not limited to, all termination blocks, equipment racks, patch panels and fiber optic enclosures
- H. Terminal backboard layout with labeling and pair identification

15.2. Provide two project manuals that are assembled in loose-leaf binders and contain the following:

- A. As Built AutoCAD prints as listed above
- B. A CD-ROM copy of all copper and fiber optic test results, including the software tools required to view, inspect and print any selection of test reports
- C. Warranty information and any vendor certification of the installed infrastructure

16. Power Supply

16.1. Power to terminal rooms shall be installed using dedicated circuits to these areas. Uninterruptable power supply (UPS) system equipment shall be incorporated only if identified and budgeted in the project in consultation with OIT.

16.2. Where UPS systems are required, the following criteria apply:

16.2.1. Space ventilation or air conditioning shall be provided to maintain recommended operating temperature of equipment.

16.2.2. The systems shall be completely isolated from the line. The neutral shall be bonded to ground.

16.2.3. Voltage spikes shall have attenuation of 2,000:1 from line for lightning protection. Surges shall be suppressed as described per IEEE 587 A and B to safe levels (guide to surge voltages).

16.2.4. Common mode noise rejection shall be better than 120 dB. Transverse mode noise rejection shall be greater than 60 dB.

16.2.5. The voltage regulation shall be greater than 3 percent.

16.2.6. The wave shape shall be Sine. It shall be limited to 3 percent maximum single harmonic distortion, and 5 percent total harmonic distortion.

16.2.7. Loss of power shall be less than 2 milliseconds in transfer to the UPS and return. The waveform shall remain in phase.

16.2.8. The unit shall run without input power for 20 minutes full load. OIT shall review this time frame.

16.2.9. There shall be a method of bypassing AC so the UPS may be maintained and repaired without loss of power to equipment. It is not necessary to condition power in this mode.

16.2.10. The UPS shall be capable of handling a 25 percent overload for five minutes, and a surge overload of 50 percent.

16.2.11. There shall be a delay of more than 15 seconds before the UPS returns to normal line conditioning mode.

16.2.12. The output waveform shall have less than 3 percent maximum single harmonic distortion, and 5 percent total harmonic distortion.

17. Private Local Area Networks

17.1. Private Local Area Networks are independent data networks that are operated by an individual university department, other than OIT, for its own specific data needs.

17.2. OIT shall provide a connection to the university Wide Area Network at the LAN administrator's request, which OIT has installed and is maintained.

17.3. Horizontal and vertical fiber-optic and copper wiring are considered part of the building infrastructure and therefore OIT responsibility. Departments that wish to operate their own private LAN shall include OIT in the planning and design of their network to ensure compatibility, so OIT is prepared to provide any necessary technical or equipment support. OIT shall provide access to the horizontal wiring infrastructure within the private LAN area that the private LAN administrator requests.

17.4. Access shall be provided using a termination block that is capable of providing the level of service that the private LAN administrator requests. The termination block is necessary to isolate the private LAN from OIT voice and data equipment.

17.5. All equipment, including racks, cabinets, wire management trays and electrical equipment that the private LAN administrator installs shall be done in accordance with existing building and electrical codes. Compliance includes all university and state permits where applicable, which include observance of all working clearances and equipment grounding requirements.

18. Products Installed that are not Covered by These Standards

18.1. University departments that purchase their own equipment, goods and services shall consult with OIT before such purchases to ensure that OIT is able and prepared to provide support.

18.2. OIT cannot guarantee that voice and/or data wiring (including all associated termination hardware, electrical or electronic equipment, installation services or maintenance agreements) that deviate from these standards will be interoperable with current or future network designs.

18.3. Furthermore, deviation from these standards limits the ability of OIT to support said installation. OIT shall provide its best effort in support, although it should be recognized that the normal response and resolution metrics of OIT shall not apply.

18.4. OIT is not responsible for promises of performance, guarantees or warranties implied or written that manufacturers or contractors make to non-OIT departments. If possible, OIT shall provide support to university departments that purchase their own equipment. OIT shall train department engineers and technicians at the department's expense, as well as stock additional equipment necessary for adds, moves or changes, testing and repair. Long lead times on non-standard equipment are possible.

19. Definitions of Abbreviations Contained in these Standards

- A. **ANSI** - American National Standards Institute
- B. **BICSI** - Building Industry Consulting Services International
- C. **CABO** - Council of American Building Officials
- D. **CMP** - Communications Plenum Cable

- E. **CMR** - Communications Riser Cable
- F. **EIA** - Electronic Industry Association
- G. **IEC** - International Electromechanical Commission
- H. **ISO** - International Organization for Standardization
- I. **NEC** - National Electric Code
- J. **NECA** - National Electrical Contractors Association
- K. **NEMA** - National Electrical Manufacturers Association
- L. **NFPA** - National Fire Protection Association
- M. **OIT** - University of Minnesota, Office of Information Technology
- N. **PBX** - Primary Branch Exchange
- O. **TIA** - Telecommunications Industry Association
- P. **UL** - Underwriters Laboratories

(c) 2002 by OIT and the Regents of the University of Minnesota
The University of Minnesota is an equal opportunity educator and employer.